

## SPECIFICATION AND DESCRIPTION



# GRAND CARAVAN EX



TEXTRON AVIATION

February 2016

Revision D  
Units 208B-5265 to TBD

# SPECIFICATION AND DESCRIPTION



UNITS 208B-5265 TO TBD

FEBRUARY 2016

REVISION D

## INTRODUCTION

This “Specification and Description” is published for the purpose of providing general information for the evaluation of the design, performance and equipment of the Cessna Grand Caravan EX aircraft. Should more detailed data be required, it can be obtained by contacting:

Cessna Aircraft Company  
P.O. Box 7704  
Wichita, Kansas 67277  
Telephone: 316-517-6081  
Fax: 316-517-7850

This document describes only the Cessna Model 208B Grand Caravan EX aircraft, Unit Serial Number 5265 and on, and its powerplant and equipment.

Also included is the Cessna warranty applicable to the Cessna Model 208B Grand Caravan EX aircraft and the Caravan Crew Training Agreement. In the event of any conflict or discrepancy between this document and the basic purchase agreement to which it may be appended, terms specified in the basic purchase agreement govern.

Due to the time span between the date of this Specification and Description and the scheduled delivery date of the aircraft, Cessna reserves the right to revise the “Specification and Description” whenever occasioned.

**WARNING:** This product contains Halon 1211, Halon 1301, and also R-134A. Furthermore, the product was manufactured with CFC-12 and 1-1-1 Trichloroethane, substances which harm public health and environment by destroying ozone in the upper atmosphere.

## TABLE OF CONTENTS

### CESSNA GRAND CARAVAN EX SPECIFICATION AND DESCRIPTION

SECTION	PAGE
1. General Description .....	3
2. Performance .....	7
3. Structural Design Criteria .....	8
4. Fuselage Group .....	8
5. Wing Group .....	9
6. Empennage Group .....	9
7. Landing Gear .....	10
8. Propulsion	
8.1 Powerplant .....	10
8.2 Propeller .....	11
9. Systems	
9.1 Flight Controls .....	11
9.2 Fuel System .....	12
9.3 Electrical System .....	12
9.4 Lighting System .....	12
9.5 Environmental System.....	13
9.6 Pitot-Static System .....	13
9.7 Vacuum System .....	13
9.8 Garmin G1000 Avionics System .....	13
10. Floatplane .....	14
11. Standard Equipment	
11.1 Avionics .....	17
11.2 Engine Instruments .....	17
11.3 Flight Instruments .....	17
11.4 Flight Controls .....	17
11.5 Environmental .....	18
11.6 Electrical Power .....	18
11.7 Exterior Lights.....	18
11.8 Interior Lights .....	18
11.9 Powerplant.....	18
11.10 Fuel System.....	18
11.11 Interior.....	19
11.12 Exterior.....	19
12. Documentation and Technical Publications .....	20
13. Maintenance Programs .....	21
14. Limited Warranties	
14.1 Cessna Grand Caravan EX Limited Warranty .....	22
14.2 Pratt & Whitney Canada Inc. ....	23
14.3 Honeywell/Bendix/King Warranty .....	23
14.4 Hartzell Limited Warranty .....	25
15. Grand Caravan EX Crew Training Agreement.....	27
FIGURE I — GRAND CARAVAN EX EXTERIOR DIMENSIONS .....	4
FIGURE II — GRAND CARAVAN EX INTERIOR DIMENSIONS .....	5
FIGURE III — GRAND CARAVAN EX INSTRUMENT PANEL AND PEDESTAL LAYOUT .....	16

# 1. GENERAL DESCRIPTION

## 1. GENERAL DESCRIPTION

The Cessna Grand Caravan EX is an unpressurized single-engine high wing turboprop aircraft with fixed landing gear. The aircraft can accommodate up to 14 persons including a minimum crew of one. (Operations with more than nine passengers must be approved by the registering country’s aviation authority.) Suitable allowance for luggage and optional equipment is also provided.

The powerplant is a Pratt and Whitney of Canada PT6A-140 turboprop engine mounted in the nose of the aircraft fuselage.

POWERPLANT ..... Pratt & Whitney PT6A-140 867 shp @ 1900 rpm

PROPELLER..... Hartzell, Constant Speed, Full Feathering, Reversible Pitch, 3 Blades, 106 in. Diameter

## LOADING

Wing ..... 31.49 lb/ft<sup>2</sup>

Power ..... 10.15 lb/shp

## 1.1 CERTIFICATION

Certification basis is to U.S. FAA FAR Part 23 Requirements—day, night, VFR, IFR and flight-into-icing conditions when equipped with the appropriate options. Export certification requirements may require additional equipment and charges.

## 1. GENERAL DESCRIPTION (CONTINUED)

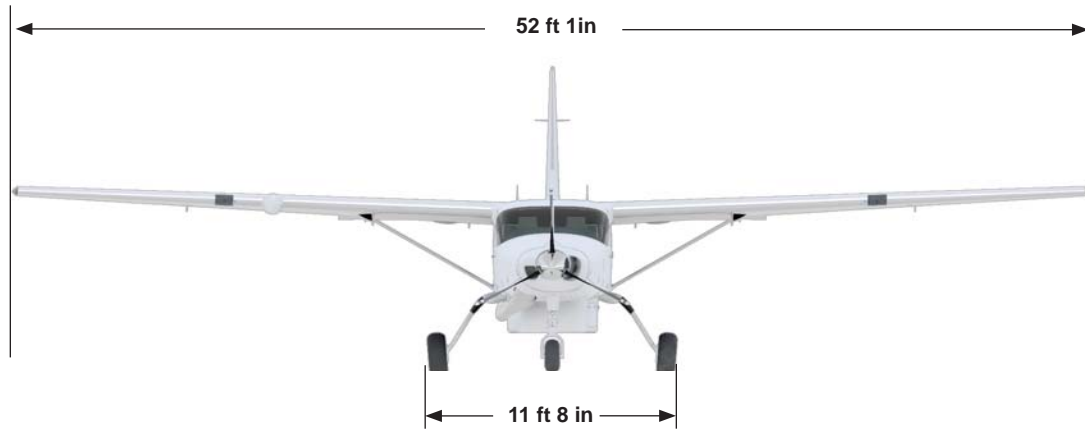

**NOTES:**

1. Dimensions shown are based on standard empty weight and proper inflation of nose and main gear tires.

2. Wing span dimension includes strobe lights.

3. Maximum height shown with nose gear depressed as far as possible.

4. Wheel base length is 13'-3 1/2".

5. Wing area is 279.4 square feet.

6. Minimum turning radius (\* pivot point to outboard wing tip strobe light) is 33'-8".

7. Hartzell propeller ground clearance with standard tires and extended nose gear strut:

Nose tire inflated and nose gear barrel extended 3 5/8": 14 3/4".

Nose tire deflated and nose strut fully compressed: 5 7/8".



FIGURE I — GRAND CARAVAN EX EXTERIOR DIMENSIONS

(Shown with Optional Cargo Pod Installed)

# 1. GENERAL DESCRIPTION (CONTINUED)

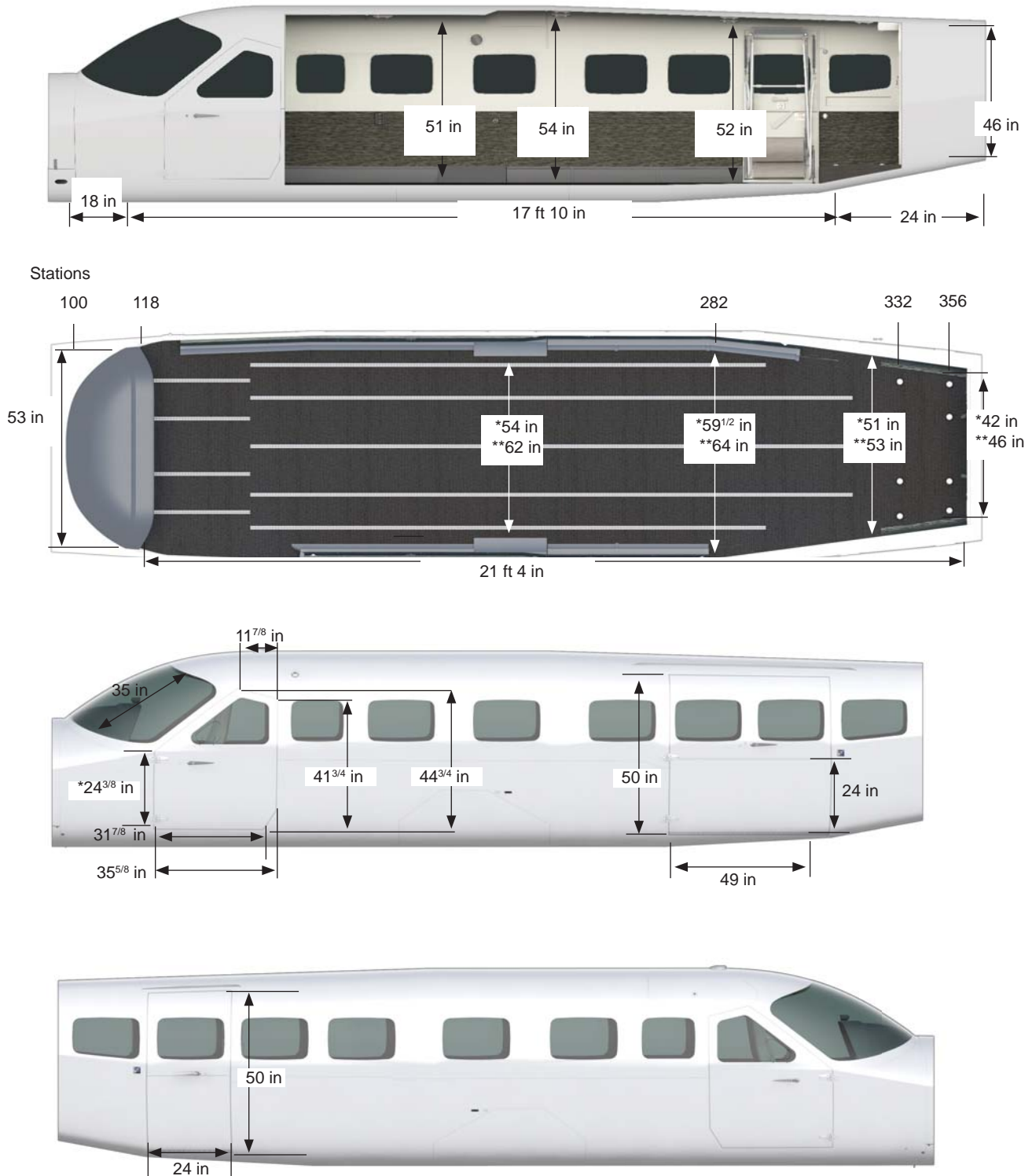

FIGURE II — GRAND CARAVAN EX INTERIOR DIMENSIONS

## 1. GENERAL DESCRIPTION (CONTINUED)

### 1.2 APPROXIMATE DIMENSIONS

Overall Height .....	15 ft 1 in
Overall Length .....	41 ft 7 in

#### WING

Span .....	52 ft 1 in
Area .....	279.40 ft <sup>2</sup>
Sweepback (at 50% chord) .....	0 degrees
Dihedral .....	+3 degrees
Taper Ratio .....	0.586
Aspect Ratio .....	9.555
Mean Aerodynamic Chord.....	66.474 in

#### HORIZONTAL TAIL

Span (overall) .....	20 ft 6 in
Area .....	70.04 ft <sup>2</sup>
Sweepback .....	0° at elevator hinge line
Aspect Ratio .....	6.0
Mean Aerodynamic Chord .....	41.984 in

#### VERTICAL TAIL

Height (overall) .....	8 ft 2 in
Area (including dorsal fin) .....	39.92 ft <sup>2</sup>
Sweepback .....	+9.437° at rudder hinge line

#### CABIN INTERIOR

Height (floorboard to headliner) .....	4 ft 3 in
Length - Firewall to Aft Bulkhead (nominal) .....	21 ft 4 in
Width (max.) .....	5 ft 2 in

#### LANDING GEAR

Tread .....	11 ft 8 in
Wheelbase .....	13 ft 3.5 in
Tire Size - Main .....	8.5 x 10, 8 ply
Tire Size - Nose .....	22 x 8.00 x 8, 6 ply



# 1. GENERAL DESCRIPTION (CONTINUED)

## 1.3 DESIGN WEIGHTS AND CAPACITIES

Maximum Ramp Weight .....	8842 lb
Maximum Takeoff Weight .....	8807 lb
Maximum Landing Weight .....	8500 lb
Standard Empty Weight* .....	4558 Est. lb
Maximum Useful Load .....	4284 Est. lb
Fuel Capacity (usable) at 6.70 lb/gal .....	335.6 gal/2,246 lb
Oil .....	14 qt

\* Approximate standard empty weight includes unusable fuel, full operating fluids and full engine oil.

# 2. PERFORMANCE

All performance data is based on a standard aircraft configuration in International Standard Atmosphere conditions. Takeoff and landing field lengths are based on level, hard surface, dry runways with zero wind. Actual performance will vary with individual airplanes and other factors such as environmental conditions and aircraft configuration.

	Without cargo pod	With cargo pod
Speed (Based on weight 8,807 lbs)		
Cruise at 10,000 ft .....	195 kts	185 kts
Cruise at 20,000 ft .....	186 kts	175 kts
Range (with 2,246 pounds usable fuel and fuel allowance for engine start, taxi, takeoff, climb, descent and 45 minutes reserve)		
Maximum Cruise Power at 10,000 ft .....	832 nm	792 nm
Endurance .....	4.4 hr	4.4 hr
Maximum Cruise Power at 18,000 ft .....	1,040 nm	985 nm
Endurance .....	5.7 hr	5.7 hr
Maximum Range Power at 10,000 ft .....	973 nm	918 nm
Endurance .....	6.0 hr	6.0 hr
Maximum Range Power at 18,000 ft .....	1,125 nm	1,052 nm
Endurance .....	6.8 hr	6.6 hr
Rate of Climb at Sea Level .....	1,330 fpm	1,275 fpm
Service Ceiling .....	25,000 ft	25,000 ft
Maximum Certified Altitude .....	25,000 ft	25,000 ft
Maximum Altitude in Icing Conditions .....	20,000 ft	20,000 ft
Takeoff Performance (sea level, 8,807 lb)		
Ground Roll.....	1,399 ft	1,399 ft
Total Distance Over 50 ft Obstacle .....	2,160 ft	2,160 ft
Landing Performance (sea level, 8,500 lb, no reverse)		
Ground Roll .....	1,039 ft	1,004 ft
Total Distance Over 50 ft. Obstacle .....	1,871 ft	1,836 ft
Stall Speed, CAS		
Flaps Up, Idle Power .....	78 kts	78 kts
Flaps Down, Idle Power .....	61 kts	61 kts

## 3. STRUCTURAL DESIGN CRITERIA

The Grand Caravan EX certification basis is to FAR Part 23 normal category aircraft. Design limit load factors are +3.8G, -1.52G at a maximum takeoff weight of 8,807 pounds. Ultimate loads are defined as 1.5 times the limit loads.

### DESIGN SPEEDS

(All speeds are at maximum gross weight.)

Cruising Maximum Operating Limit ( $V_{MO}$ ) .....	175 KCAS
Flap Extension Speeds	
0° to 15° .....	150 KCAS
15° to 30° .....	125 KCAS
Maneuvering Speed ( $V_A$ )	
8,807 pounds .....	148 KCAS
7,500 pounds .....	137 KCAS
6,250 pounds.....	125 KCAS
5,000 pounds.....	112 KCAS

## 4. FUSELAGE GROUP

Construction of the fuselage is of conventional formed sheet metal bulkhead, stringer and skin design. Major elements of the structure are the front carry-through spar and bulkhead, the rear carry-through spar and landing gear bulkhead, and the forward doorpost. The front carry-through spar and bulkhead is an integral fail-safe structure with forgings at the top for attaching the front wing spar and forgings at the bottom for attaching the wing strut. The rear carry-through and landing gear bulkhead is an integral fail-safe structure with forgings at the top for attaching the rear wing spar and forgings at the bottom for attaching the main landing gear trunnions. The forward doorpost provides the load path for transferring the loads from the engine mount directly to the primary structure.

The large cabin area provides comfortable space for a pilot and up to thirteen passengers. (Operations with more than nine passengers are limited to countries that issue approval.) Inside cabin dimensions are 51" high and 62" wide at the front and rear spar bulkhead locations. The cabin narrows slightly toward the tailcone to 52" high and 53" wide just aft of the cargo door. Total length of the cabin from the firewall to the aft bulkhead is 21 ft. 4 in. The cabin floor is flat with the exception of two feet in the aft cabin which is five inches above the main floor and makes up the aft cabin baggage area.

Cabin volume, including the pilot and aft cabin baggage area is 427 cubic feet. Total volume aft of the pilot and front passenger seat locations is approximately 340 cubic feet.

Entry to, and exit from the airplane is accomplished through an entry door on each side of the cabin at the pilot and front passenger seat location and through a two piece airstair-type door on the right side of the airplane just aft of the wing. A large cargo door is also provided on the left side of the airplane directly across from the airstair door. All doors can be opened with the flaps up or down.

The left crew entry door incorporates a conventional door handle, key-operated door lock, conventional interior door handle and window with a small triangular foul weather window. The foul weather window may be opened for additional ground ventilation. The right crew entry door incorporates a conventional outside and inside door handle and a manually operated inside door lock. A 4 inch deep x 5 1/2 inch storage area is incorporated into the interior width of both the left and right crew doors. Both doors have a maximum width of 35.65 inches and a maximum height of 44.75 inches and will open 180 degrees forward to latch against the side of the fuselage.

## 4. FUSELAGE GROUP (CONTINUED)

The passenger entry door consists of an upper and lower section. When opened, the upper section swings upward and the lower section drops down providing integral steps to aid in boarding or exiting the airplane. The door opening is approximately 24 inches wide and 50 inches high.

A two-piece cargo door is installed on the left side of the airplane aft of the wing trailing edge. The cargo door is divided into an upper and lower section. When opened, the upper section swings upward and the lower section opens 180 degrees forward providing a large 49 inch wide by 50 inch high opening in the side of the fuselage which facilitates the loading of bulky cargo into the cabin.

The door opening is flush with the floor and has square corners for maximum cargo loading capability.

The airplane is equipped with a two-piece plexiglass windshield reinforced with a metal center strip. Sixteen side windows of the fixed type are installed in the cabin sides including one each in the two crew entry doors, two windows in the upper section of the cargo door and one window in the upper section of the passenger entry door. The windshield and forward crew door windows are 5/16 inch and 1/4 inch thick respectively. All other windows are 3/16 inch thick tinted plexiglass.

## 5. WING GROUP

The Grand Caravan EX utilizes conventional wings with NACA 23000 Series Airfoils. The externally braced, fail-safe wings are constructed of front and rear spars with formed sheet metal ribs, doublers and stringers. The entire structure is covered with aluminum skin.

The primary wing spars, wing carry-through spars in the fuselage and attaching structure are of fail-safe construction for limit flight loads. Fail-safe construction assures that the structure is designed and built in such a way that should any single structural component fail, the remaining structure is capable of carrying certified limit flight loads.

## 6. EMPENNAGE GROUP

The empennage consists of a conventional vertical stabilizer, rudder, horizontal stabilizer and elevator, all of which are constructed of a forward and aft spar with formed sheet metal ribs and aluminum skin panels. The horizontal stabilizer contains dual jack screw type actuators for operating the

elevator trim tabs. An elevator trim tab is attached to each elevator by full length piano-type hinges. Stabilizer abrasion boots are installed along the leading edge of the horizontal stabilizer.

## 7. LANDING GEAR

The landing gear is of the non-retracting, tricycle type with a steerable nose wheel and two main wheels. Shock absorption is provided by the tubular spring steel main landing gear struts with an inter-tube connecting the two outer tubes. The tires are tube type; standard nose tire is 22 x 8.00 x 8, 6 ply and main gear tires are 8.50 x 10, 8 ply. The nose gear tire is mounted on an extended nose gear strut providing 14 3/4 in. ground clearance. The nose gear shock absorption is provided by the oil snubber combined with a drag link spring providing vertical and aft displacement

restraint. Each main gear wheel is equipped with a hydraulically actuated four piston brake.

Nose gear steering is accomplished by using the rudder pedals which turns the nose wheel through an arc of approximately 15° each side of center. By applying either left or right brake, the degree of turn may be increased up to 51.5° each side of center. The minimum turning radius of the airplane, using differential braking and nose wheel steering during taxiing, is 33 feet 8 inches.

## 8. PROPULSION

### 8.1 POWERPLANT

The propulsion system consists of a single fuselage mounted Pratt and Whitney PT6A-140 turboprop engine. The PT6A-140 is rated to 867 shp at 1900 rpm. The standard time between overhaul for this engine is 3600 hours.

Conventional turboprop controls are used to operate the engine and propeller. They consist of a power lever, emergency power lever, propeller control lever and a fuel condition lever. The power and fuel condition levers are engine controls while the propeller control lever controls propeller speed. An emergency power lever is provided to manually control fuel supply to the engine should a malfunction occur in the fuel control unit.

Engine operation is monitored by the engine indication system (EIS) which shows numeric readouts of critical engine, fuel and electrical indications for the following: torque, propeller speed, interstage temperature (ITT), gas generator % RPM (Ng), fuel flow, oil pressure and oil temperature. A wet type standby engine torque gauge is also installed. Engine torque is limited by a sensor that reduces fuel flow if an over torque occurs.

An inertial separator system is built into the engine air inlet duct to prevent moisture particles from entering the engine

inlet plenum. The inertial separator system is mechanically controlled by a push-pull handle located on the left side of the instrument panel. Engine ignition is provided by two igniters that are energized by a dual channel ignition exciter mounted on the right side of the engine compartment. Mounting provisions are provided for a standby ignition exciter unit.

A P&WC FAST Engine Trend Monitor is an engine trend recording device and an engine parameter exceedance monitor which will allow operators to monitor the health of the engine through periodic sampling of engine parameters. The engine trend monitor contains logic to determine when the aircraft is in a stable cruise flight regime before automatically taking a trend sample. If an optional SIM card is installed and the GSM feature is activated through P&WC the data is automatically uploaded via built-in cell phone transmitter after landing.

This is an advisory system only. The airplane's engine indication system is still the primary source of detecting and correcting conditions where engine limitations are exceeded. There are no additional aircraft limitations and no performance change with the P&WC FAST Engine Trend Monitor installed.

## 8. PROPULSION (CONTINUED)

### 8.2 PROPELLER

The Grand Caravan EX is equipped with a 106 inch diameter metal propeller. The three-blade, constant speed, full feathering, single acting, reversible pitch propeller is manufactured by Hartzell, model HC-B3TN-3AF(Y). The propeller is controlled by a propeller governor and an overspeed governor mounted on and driven by the reduction gear-box. The overspeed governor acts as a safeguard against propeller overspeed should the primary propeller governor fail.

## 9. SYSTEMS

### 9.1 FLIGHT CONTROLS

The Grand Caravan EX's flight control system consists of conventional aileron, elevator and rudder control surfaces. In addition, a pair of slot lip spoilers are mounted above the outboard ends of the flaps. The control surfaces are manually operated through mechanical linkage using a control wheel for the ailerons, spoilers and elevator and rudder/brake pedals for the rudder.

The rudder control utilizes a rudder pedal cable system driving the rudder. The floor mounted rudder bars are gear interconnected to maintain cable tension. Conventional design of inner torque tubes serve to allow co-pilot operation of the left-hand mounted brake cylinders. The brake cylinders have a remote reservoir mounted on the forward side of the engine firewall for convenient access.

Rudder trim system consists of a trim wheel driving a flex shaft which, in turn, adjusts rudder pressure.

The elevator control system features a conventional cable drive system. The elevator is connected to the cables by a bellcrank and push-pull rod.

Elevator trim is accomplished through two elevator trim tabs by utilizing the vertically mounted trim control wheel on the control pedestal. An electric elevator trim system is available with the standard autopilot installation.

The aileron control system is a combination of cables, quadrants, bellcranks and push-pull rods. A push-pull rod drives the ailerons.

An aileron trim system consists of a pedestal mounted control knob, cables, fail-safe actuator, pushrods and trim tabs. The left aileron incorporates a servo tab while the right aileron incorporates a trimmable servo tab.

A pair of slot lip spoilers mounted above the outboard ends of the flaps are incorporated to improve low speed roll control. The spoilers are interconnected with the aileron system through a pushrod mounted to an arm on the aileron bellcrank. Spoiler travel is proportional to aileron up travel.

The single slotted, semi-fowler flaps are electrically driven and incorporate a trailing edge angle with leading edge vortex generators to reduce stall speed and provide enhanced lateral stability. A selector and mechanical type follow-up indicator is provided in the control pedestal. The flap system consists of an electrically driven screwjack actuator, a primary and standby motor, and a system of cables, bellcranks and pushrods connected to the flaps. The standby electric drive motor provides back-up flap actuation in the event of failure of the primary motor.

## 9. SYSTEMS (CONTINUED)

### 9.2 FUEL SYSTEM

The Grand Caravan EX fuel system consists of two vented integral fuel tanks (one in each wing formed by the front and rear spars), a fuel reservoir, engine fuel system, quantity and flow instrumentation, and the necessary lines, controls, valves and pumps to complete the system. Fuel system capacity is 339.1 U.S. gallons (335 gallons usable). Filling the fuel tanks is accomplished through filler caps in each wing.

Normal operation is with both tanks on. The pilot can mechanically select fuel from either left or right fuel tanks or both at the same time.

Fuel quantity is measured by four fuel level probes (two in each wing tank) and indicated on the engine indication system (EIS). The fuel quantity system is calibrated in gallons based on 6.7 pounds per gallon. Fuel quantity indications are displayed in pounds. Wing fuel level caution advisories, one for each wing tank, are provided through the crew advisory system (CAS). The appropriate FUEL LOW (CAS) message will illuminate when the fuel in the respective tank is approximately 25 gallons or less. A warning advisory is also provided to indicate a low fuel level in the fuel reservoir tank.

### 9.3 ELECTRICAL SYSTEM

The Grand Caravan EX is equipped with a 28-volt, direct-current electrical system. The system uses a 24-volt, 38 ampere-hour sealed lead acid battery as a source of electrical energy and a 200-amp engine-driven starter generator. (An optional 300-amp engine-driven starter generator is available.) Power is supplied to most general electrical and all avionics circuits through two general buses, two avionics buses and a battery bus. The battery bus is energized continuously for ELT reset, Hobbs Meter, cabin/courtesy light functions and engine trend monitor processor.

A generator control unit provides the electrical control function necessary for the operation of the starter-generator.

Electrical system operation can be monitored on the Engine Indication System (EIS) display on the MFD (in normal mode). Battery Amps and Bus Volts can be viewed on either EIS page (Engine or System). Generator and (Standby) Alternator Amps can be viewed on the EIS System page. The Crew

Alerting System (CAS) Annunciation Window is located on each Primary Flight Display (PFD) and can present appropriate messages (i.e. warning, caution and advisory) pertaining to various engine and aircraft systems as may be applicable.

A standard ground service plug receptacle permits the use of an external power source for cold weather starting or during maintenance work. Ground service circuitry is provided to prevent the external power and the battery from being connected together during starting, and incorporates polarity reversal and overvoltage protection. The external power receptacle is installed on the left side of the engine compartment near the firewall.

A standby electrical system is installed for use as a standby power source in the event the main generator system malfunctions in flight. The system includes a belt-driven alternator operated at a 75-amp capacity rating.

One automotive-style 12-volt power outlet is located in the cockpit. Two cabin power outlets are also included.

### 9.4 LIGHTING SYSTEM

Exterior LED lighting consists of two navigation lights, two landing lights, two taxi/recognition lights, two strobe lights, a flashing beacon and two underwing courtesy lights. All exterior lights are controlled by toggle switches located on the lighting control panel on the left side of the instrument panel.

The G1000 displays and bezels, the audio panel and the autopilot control utilize either automatic or manual means of lighting control, based on crew setting of the "Avionics" potentiometer. The panel mounted G1000 equipment will revert to automatic dimming using GDU bezel photocell input when the "Avionics" knob is near the extreme CCW position. Moving the potentiometer clockwise places the G1000 panel equipment into manual mode of selection for display brightness throughout the rest of its travel. Other lighting is provided for standby instruments and other non-G1000 avionics, pilot and co-pilot control wheel map lights, LH, Center and RH flood lights, cabin/courtesy lights, passenger reading lights and a no smoking/seat belt advisory sign. All interior lighting is LED with the exception of pilot and copilot control wheel map lights.

## 9. SYSTEMS (CONTINUED)

### 9.5 ENVIRONMENTAL SYSTEM

The temperature and volume of airflow to the cabin is regulated by the cabin heating, ventilating and defrosting system. In the heating system, hot engine compressor outlet air is routed through system components to obtain the correct air temperature before air is routed to the cabin air distribution system. Controls are provided to direct the heated air to the forward and/or aft portions of the cabin for heating and to the windshield for defrosting.

Outside ventilating air is obtained from an inlet on each side of the forward fuselage and through two ram air inlets, one on each wing at the upper end of the wing struts. The wing ventilating air is routed through the wing into a plenum chamber located in the center of the cabin top. The plenum distributes the ventilating air to individual overhead outlets at each seat position. The forward fuselage ram air inlets provide ventilation through panel outlets to the flight deck.

A fan driven ventilation system provides supplemental cabin ventilation through two overhead mounted ventilators. An optional air conditioning system is available that provides comfortable cabin temperatures during hot weather operations, both on the ground or in flight.

### 9.6 PITOT-STATIC SYSTEM

The left hand pitot-static system supplies ram air and static pressure to the number one ADC (Air Data Computer) and to the standby airspeed indicator. It also provides static pressure to the standby altimeter. The system is composed of a heated pitot-static tube mounted on the leading edge of the left wing, a static pressure alternate source valve, a drain valve located behind the instrument panel and the associated plumbing necessary to connect the instruments and sources.

The right hand pitot-static system supplies ram air and static pressure to the number two ADC. The system is composed of a heated pitot-static tube mounted on the leading edge of the right wing, a drain valve located behind the instrument panel, and associated plumbing.

### 9.7 VACUUM SYSTEM

A vacuum system provides the suction necessary to operate the standby attitude indicator. Vacuum is obtained by passing regulated compressor bleed air through a vacuum ejector. The vacuum system consists of the bleed air pressure regulator, a vacuum ejector, a vacuum relief valve, and a vacuum system air filter. Vacuum system failure is indicated via a warning flag on the standby attitude indicator.

### 9.8 GARMIN G1000 AVIONICS SYSTEM

The integrated avionics system incorporates 3 ten-inch displays; the pilot's primary flight display (PFD), the multi-function display (MFD) and the co-pilot's PFD. The system includes a single audio system control panel and a separate autopilot controller.

The fully integrated Garmin G1000 system will provide the following communication/navigation/surveillance (CNS) functions: Dual VHF NAV/Glideslope/Localizer receivers, dual VHF com transceivers, dual WAAS GPS receivers and Mode S Transponder. The KN-63 DME can be selected to either NAV1 or NAV2 via PFD softkeys. Crew alerts are displayed on the PFDs.

The automatic flight control system (AFCS) incorporates a GFC-700 three-axis autopilot with pitch trim and GFC-710 autopilot controller.

Avionics cooling is provided by two cowl deck fans and three display fans. The cowl deck fans are powered from the electrical bus. The display fans provide cooling air to each of the three display units and are powered from the display power circuits.

Avionic circuit breakers are located on an exclusive panel located on the lower left-hand instrument panel.

# 10. FLOATPLANE

The Grand Caravan EX floatplane provisions consist of hoisting rings, inboard fuel filling ports, extended chord rudder, short airstair door cables (loose equipment), and microphone relocation.

The hoisting rings include four rings which attach to the left and right sides of both the front and rear spar wing-to-fuselage attach fittings. To gain access to the hoisting rings, it is necessary to remove the wing-to-fuselage fairing strips. Inboard fuel ports with anti-siphon doors provide an easily accessible fuel filler location when refueling on floats. Due to wing dihedral, use of inboard filler ports for refueling will reduce maximum usable fuel to 240 gallons. The extended chord rudder increases the surface area of the rudder to provide greater control when floats are installed on the aircraft. The hand microphone is located on the center pedestal to allow clearance for the emergency lever that is used to manually lower the wheels on the floats.

## WIPLINE 8750 FLOAT INSTALLATION

The Caravan can be converted to a floatplane or an amphibian when equipped with Wipline 8750 Series Floats manufactured, installed, and warranted by Wipaire, Inc. (The optional 300-amp starter/generator is not compatible with this installation.)

The floats are part of a Wipaire, Inc. STC and are installed by Wipaire, Inc. after aircraft acceptance and delivery from Cessna Aircraft Company. Wipline floats are FAA certified and TSO approved, and meet Federal CAR-3.372 buoyancy regulations for flooded compartments.

For additional information contact:

Wipaire, Inc.  
1700 Henry Avenue, Fleming Field,  
South St. Paul, MN 55075  
(651) 451-1205  
(651) 457-7875 fax  
info@wipaire.com  
<http://www.wipaire.com>.



## 10. FLOATPLANE (CONTINUED)

The Following Performance Figures Are Provided By Wipaire, Inc. And Have Not Been Tested By Cessna Aircraft Company.

### SPECIFICATIONS FOR THE 8750 AMPHIBIOUS FLOAT

#### DIMENSIONS (EXTERNAL)

Length (nose of float to extended water rudder) .....	31'-9"
Height - hull .....	3'-3"
Width - hull .....	3'-6"

#### WEIGHT

Amphibious 8750 on the Cessna 208B Grand Caravan EX .....	1,678 lbs/1,142 lbs*
---	----------------------

\*Exchange = Float installation weight minus aircraft landing gear weight.

### PERFORMANCE FOR THE 8750 AMPHIBIOUS FLOAT - CESSNA 208B GRAND CARAVAN EX PT6A-140 (867 HP)

Cruise Speed (75%) .....	159 KTAS
Take off run (land) .....	1,826 ft
Take off over 50 ft. obstacle (land) .....	2,425 ft
Take off run (water) .....	2,000 ft
Take off over 50 ft. obstacle (water) .....	3,270 ft
Rate of climb .....	1,212 ft/min
Service ceiling .....	20,000 ft
Gross weight (land & water) Requires Wipaire Gross Weight Kit STC .....	9,062 lbs
Landing weight (land) Requires Wipaire Gross Weight Kit STC .....	9,062 lbs
Landing weight (water) Requires Wipaire Gross Weight Kit STC .....	9,062 lbs
Maximum take off weight .....	9,062 lbs
Maximum range* (cruise speed, 10,000 ft) .....	820 nmt
Stall speed (landing configuration) .....	59 KCAS

Standard Empty Weight (Estimated) .....	Amphibian 5,800 lbs
Maximum Useful Load (Estimated) .....	3,262 lbs

\*Range based on 332 gal. usable fuel and includes takeoff, climb, descent and 45 minute reserve.

# 11. STANDARD EQUIPMENT



FIGURE III — GRAND CARAVAN EX INSTRUMENT PANEL AND PEDESTAL LAYOUT

(Some options may be shown)

# 11. STANDARD EQUIPMENT (CONTINUED)

## 11.1 AVIONICS

Standard Avionics Kit (includes Two Headsets)

**Garmin G1000 System includes:**

- GDU 1040A Pilot & Co-Pilot Primary Flight Display (PFD)
- GDU 1040A Multi Function Display (MFD)
- GDC 74A Dual Air Data Computer (ADC)
- GEA 71 Engine/Airframe Unit
- GIA 63W Dual Integrated Avionics Unit (Includes Comm, Nav, GPS)
- GRS 77 Dual Attitude and Heading Reference System (AHRS)
- GMA 1347 Single Audio System with Integrated Marker Beacon Receiver
- GMC 710 Autopilot Mode Controller
- GSA 80/81 Servo Actuators with GSM 86 Servo Mounts
- GTX 33 Mode S Transponder
- Garmin Relative Terrain/Obstacles
- Garmin Flight Charts Capable
- Garmin Safe Taxi Capable
- KN-63 DME
- Switch, Avionics Power (Two) (On-Off)
- Artex ME-406 2-Frequency (Non -Nav Interfaced) ELT with Remote Switch and Monitor Light (Dorsal Fin Installation)
- Avionics Cooling, (2) cowl deck fans and (3) display fans
- PA System with Aft Cabin Speakers
- Intercom
- Cabin Headset Jacks

## 11.2 ENGINE INDICATION SYSTEM (EIS)

**Displayed on MFD During Normal Operations:**

**Engine and System Displays - Show numeric readouts of critical engine, fuel and electrical indications and calculations for the following:**

- Torque
- Interstage Turbine Temperature
- Gas Generator Speed
- Propeller Speed
- Oil Pressure
- Oil Temperature

- Fuel Quantity
- Fuel Flow
- Ammeter/Voltmeter
- Standby Engine Instrument
- Engine Torque Gauge, Wet Type
- Digital FAST Engine Trend Monitoring System

## 11.3 FLIGHT INSTRUMENTS

**Indications Displayed on each PFD:**

- Airspeed
- Attitude with Slip/Skid Indication
- Altitude
- Vertical Deviation, Glideslope and Glidepath
- Vertical Speed
- Horizontal Situation Indication
- Outside Air Temperature
- System Time
- Generic Timer
- Wind Data
- Standby Flight Instruments:
  - Airspeed Indicator
  - Attitude Gyro
  - Altimeter
- Magnetic Compass,
- Heated Pitot System, Pilot & Co-Pilot
- Alternate Static Source
- Static Source Drains
- Instrument Static System
- Second Independent Pitot-Static System

## 11.4 FLIGHT CONTROLS

- Brake, Parking
- Brakes, Hydraulic, Toe-Operated
- Control Cables — Corrosion Resistant Steel
- Control Lock, Ailerons and Elevator
- Flight Control System, Pilot & Co-Pilot (Includes All-Purpose Control Wheel, Pedals and Toe Brakes)
- Friction Lock, Engine Controls
- Powerplant, Quadrant Type Controls:
  - Condition Lever

## 11. STANDARD EQUIPMENT (CONTINUED)

Primary Engine Power

Back-Up Engine Power, (Emergency Power Lever)

Propeller, Speed and Feather

Rudder Gust Lock

Trim System (Aileron/Rudder (Manual), Elevator (Manual & Electric Pilot & Co-Pilot)

Wing Flaps, Electric Pre-Select with Standby Motor

### 11.5 ENVIRONMENTAL

Defroster, Windshield (Pilot and Copilot)

Heating System, Cabin (Bleed Air Type)

Soundproofing

Ventilation System, Cockpit (Ram Air)

Ventilator, Adjustable, Cabin Air

Ventilation System, Fan Driven

### 11.6 ELECTRICAL POWER

Battery, 24 Volt, 38 Amp/Hr, Sealed Lead-Acid

Battery Switch (On-Off)

Circuit Breakers, Electrical

Generator Control Unit

Generator Switch (Trip-On-Reset)

Ground Service Plug Receptacle

Starter/Generator, 200 Amp

Power Outlet, 12V Cockpit And Cabin

Standby Electrical System, 75 amp

### 11.7 EXTERIOR LIGHTS (LED)

Beacon – Omni Flash (Red)

Courtesy, Under Wing

Landing, L.H. and R.H. (Wing Leading Edge-Outboard)

Navigation (2)

Strobe (2) Wing Tip Mounted

Taxi, L.H. and R.H. (Wing Leading Edge-Inboard)

Ice Detection

### 11.8 INTERIOR LIGHTS (LED)

LED Backlit Instrument Panel Lighting

Map Light, Control Wheel Mounted, Pilot & Co-Pilot (Variable Intensity)

Overhead Courtesy (4) (Forward and Mid Cabin, Cargo

Door and Passenger Door)

Overhead Flood (Pilot and Copilot) (3)

Passenger Reading Lights (14)

Dimming Controls, Switch Panel, Avionics Circuit Breaker Panel, Left Hand Panel & Environmental Panel

### 11.9 POWERPLANT

Chip Detector Installation

Cowling, Rigid-Mounted (Quick Removable) Lower and Easily Openable Upper Sides

Cowl Locks

Engine Inlet Cover (2) and Propeller Tie-Down Sleeve

Engine, Turboprop PT6A-140, 867 SHP, 3600 TBO

Engine Wash Ring (Integral)

Engine Support, Vibration Isolation

Filter, Integral, Full Flow Oil

Fire Detection System, Engine Compartment

Ignition System Exciter Unit Mounting (Provisions for Mounting Standby Unit)

Ignition System (Dual Ignitors)

Intake Inertial Separator (Manual)

Oil Cooler, High Capacity

Overspeed Governor

Propeller, 3 Blade Aluminum, Constant Speed, Full Feathering, Reversible – Hartzell

Propeller Governor

Propeller Spinner (Polished)

Shielding, Engine Ignition

Shutdown Fuel Collector, Engine

Oil Sight Gage

### 11.10 FUEL SYSTEM

Fuel Boost Switch, Auxiliary

Fuel Caps with Anti-Siphon Doors

Fuel Control Heater, Engine

Fuel Filter with Quick Drain

Fuel Low Level Warning System

Fuel Pump, Auxiliary (Electric)

Fuel Pump, Engine

Fuel Reservoir with Quick Drain

## 11. STANDARD EQUIPMENT (CONTINUED)

Fuel Selector Valves

Fuel Shutoff Valve

Fuel Tanks

Fuel Valves, Quick Drain (8)

Fuel Vents, Non-Icing

Fuel Sampler Cup

### 11.11 INTERIOR

Aircraft Keys

Approach Plate Holder, L.H. & R.H.

Baggage Area Partition Net

Baggage Tie-Down Straps (4)

Beverage Cup Holders (Pilot and Copilot)

Cargo Tie-Down Fittings Provisions

Cargo Tie-Down Fittings (Baggage Area)

Checklist, Pilot's (Laminated)

Crew Door Storage Area RH, LH

Fire Extinguisher Cabin– Hand Type

Floor Covering, Lightweight Vinyl

Glareshield

Handbook, Customer Care, Includes Engine/Flight Logs, Warranty, Etc.

Handbook, Pilot's Operating

Headliner – Vinyl

Instrument Panel – Metal

Map/Glove Compartment

Oxygen System, Partial Installation (Consists of Difficult to Install Plumbing)

Pilot and Co-pilot Restraint – Integral 5 Point Lap and Shoulder Harness with Inertial Reel

Pilot's LH Pre-Flight Assist Handle

Plotter, Weight & Balance (Cargo & Passengers)

Pockets, Map and Storage

Recorder, Flight Hour

Seats, Pilot & Copilot, Adjustable Fore, Aft and Vertical with Articulating Recline and Arm Rest

Sign, Fasten Seat Belts & No Smoking

Step, Cabin Entrance, Retractable (RH & LH Crew Entry Doors)

Sunvisors

Window, Foul Weather, Pilot Door

Windows Tinted All-Around

### 11.12 EXTERIOR

Anti-Precipitation Static Kit

Bonding Straps, Control Surface (Aileron, Elevator and Rudder)

Cargo Pod Provisions with Twisted Stack

Corrosion Proofing, External

Door, Cargo, Two-Piece (Left Side of Aircraft, with Upper Door Unlocked Annunciator Light)

Door, Copilot (Full Opening)

Door, Pilot (Full Opening)

Door, Passenger with Airstair Feature (Right Side of Aircraft with Upper Door Unlocked Annunciator Light)

Jack Points (Fuselage and Main Landing Gear)

Landing Gear, Fixed, Nose, Steerable

Landing Gear, Fixed, Main

Lock, Key-Operated (One Key Fits All Doors)

Paint, All Over (Modified Polyurethane)

Stabilizer Abrasion Boots

Stall Warning System, Heated

Tailstand

Tires, Tube Type, 8.50 x 10, 8 ply Main; 22 x 8.00, 6 ply Nose With Extended Nose Gear Fork

Tie-Down Rings, Aircraft

Tow Bar

# 12. DOCUMENTATION AND TECHNICAL PUBLICATIONS

U.S. Standard Airworthiness Certificate, FAA8100-2; Export Certificate of Airworthiness, FAA8130-4 or Special Airworthiness Certificate FAA8130-7 as appropriate;

- Equipment List
- Weight and Balance Report
- Garmin Cockpit Reference Guide
- Pilot's Operating Handbook and FAA Approved Airplane Flight Manual
- Pilot's Abbreviated Checklist
- Log Books (Aircraft and Engines)

Additional Miscellaneous Information Concerning Engine and Airframe Support

- Passenger Briefing Cards
- Cessna CESCO Instruction Manual

## CESSNA TECHNICAL INFORMATION

Cessna makes available a complete system of manuals and catalogs for the operation and maintenance of the Grand Caravan EX. All Cessna and related technical information, as well as revision information, is listed on [www.cessnasupport.com](http://www.cessnasupport.com).

Cessna manuals are kept current through periodic revisions. Aircraft operators and designated maintenance facilities can receive these revisions, by various mediums, through a subscription service. The subscription is free for the first year to owners of new aircraft. A subscription fee is charged thereafter.

The following manuals are provided by your choice of DVD, Download, Online or iPad mobile app with the purchase of a new Caravan:

- Service Maintenance Manual
- Illustrated Parts Catalog
- Wiring Diagram Manual
- Structural Repair Manual
- Service Bulletins
- Avionics Wiring Diagram (custom diagram of the actual avionic installation)
- CesNav Weight and Balance Calculator (CLCalc)

\*Please note: for download, online and mobile app – these publications are Windows based and registration with [www.cessnasupport.com](http://www.cessnasupport.com) is required. Up to four additional user access' available.

The following materials provided by Pratt & Whitney Canada:

- Combined Engine Maintenance Manual & Illustrated Parts Catalog CD
- One set Engine Service Bulletins Including Spare Parts Bulletins and Service Information Letters (Paper)
- Free revisions coverage for one year
- Service Bulletins are also available by on-line or email subscription at [www.pwc.ca](http://www.pwc.ca) or through the Pratt & Whitney Help Desk at (800) 268-8000.

## CESSNA REVISION STATUS CHECKLIST

The Revision Status Checklist is used to verify that only the most current Cessna maintenance and aircraft publications are in use. The checklist is available online at [www.cessnasupport.com](http://www.cessnasupport.com).

## PILOT'S OPERATING HANDBOOK

Revisions to the Pilot's Operating Handbook will be mailed periodically to the registered aircraft owner on file.

## CESSNA OWNER ADVISORY

Cessna Owner Advisories provide owners of Cessna aircraft up-to-the-minute information about mandatory and beneficial service requirements and the latest in product improvements. Owner Advisories summarize new Service Bulletins or Service Newsletters and indicate any action required by the owner, the time required for the owner to comply, and the existence of any associated "credit allowances."

Cessna Owner Advisories are mailed automatically to owners of U.S. registered Cessna aircraft using the latest name and address provided to the FAA. Owner Advisories can be mailed to a different address by request, provide the subject aircraft is still covered by Cessna warranty. International owners of Cessna aircraft covered by Cessna warranty receive Owner Advisories through a complimentary subscription. After warranty expiration, international subscriptions are available, although a subscription fee will be charged.

Cessna aircraft owners may register, for free, with [www.cessnasupport.com](http://www.cessnasupport.com) to obtain a login that allows access to PDF versions of Service Bulletins and Newsletters. Weekly email notification of released service information is available with registration to the site.

## **13. MAINTENANCE PROGRAMS**

### **COMPUTERIZED MAINTENANCE RECORD SERVICE**

Seller will provide a computerized maintenance record service for one (1) full year from the date of delivery of a Grand Caravan EX to the purchaser. Currently, this service is provided by CAMP Systems International, Inc.

This service will provide owners and operators with the reports necessary for the efficient control of maintenance activities. It will provide an accurate and simple method of keeping up with aircraft components, inspections, service bulletins and airworthiness directives while providing permanent aircraft records of maintenance performed.

Reports will be available which reflect the aircraft status, upcoming scheduled maintenance and a recap of the previous month's reported maintenance activity. Semi-annual reports concerning projected annual maintenance requirements, component removal history and fleet-wide component reliability will also be available.

The on-line system is the standard service, however, a paper service is available at an additional charge. The on-line system is accessible using a local computer with Internet capability. Data is electronically transferred through Internet connections between the customer and CAMP on a regular basis to keep information up-to-date at both locations. In addition to the standard reports, customer specific reports and maintenance records can be generated at the local computer whenever the customer wishes.

### **CARAVAN INSPECTION PROGRAM**

The Caravan Inspection Program is task based, integrating all inspections into an easy to follow sequence. The benefits of the old Phase Card program are now available to all customers.

### **FLIGHT-DATA ACQUISITION, STORAGE, AND TRANSMISSION (FAST)**

Cessna has chosen the FAST system as standard equipment on the Caravan to allow operators to easily monitor and maintain the aircraft engine.

The FAST system records engine parameters, indicated airspeed, pressure altitude, outside air temperature, flight hour meter, battery voltage, and the positions of the particle separator, emergency power lever and bleed air cabin heat switch.

Data is uploaded to P&WC data analysis servers automatically by GSM cell phone signal upon engine shutdown if a SIM card is installed and the GSM subscription service is activated through P&WC. Otherwise data can be uploaded to P&WC data analysis servers via a supplied USB cable connected to a laptop. The P&WC WebECT (tm) website formats the data into customized reports for use as analysis tools.

## 14. LIMITED WARRANTIES

The standard Grand Caravan EX Aircraft Limited Warranty which covers the aircraft, other than the Pratt & Whitney Canada (P&WC) engine and associated engine accessories, the Honeywell avionics, and the Hartzell propeller which are warranted separately, is set forth below. Seller specifically excludes vendor subscription services and the availability of vendor service providers for Optional and Customer Requested Equipment (CRQ) from Seller's Limited Aircraft Warranty. Following Seller's Limited Warranty, the engine and engine accessory warranty of P&WC, the avionics warranty of Honeywell, and the propeller warranty of Hartzell are set forth. All warranties are incorporated by reference and made part of the Purchase Agreement. All warranties are administered by Seller's Warranty Department.

### 14.1 CESSNA GRAND CARAVAN EX LIMITED WARRANTY (LIMITED WARRANTY)

Seller expressly warrants each new Grand Caravan EX Aircraft (exclusive of engine and engine accessories supplied by P&WC, avionics supplied by Honeywell, and the propeller supplied by Hartzell which are covered by their separate warranties), including other factory-installed avionics and other factory-installed optional equipment to be free from defects in material and workmanship under normal use and service for the following periods after delivery:

- (a) One (1) year unlimited hours OR two (2) years /1,000 hour limit on all aircraft components manufactured by Seller;
- (b) Five years or 5,000 operating hours, whichever occurs first, for Garmin avionics;
- (c) One year for all Optional Avionics;
- (d) One year for Actuators, Brakes, GCUs, Starter Generators, Valves, Windshields, and Vendor items including engine accessories supplied by Seller unless otherwise stated in the Optional Equipment and Selection Guide;
- (e) One year for CRQs, Interior Components, Interior Furnishings, and Paint.

Any remaining term of this Limited Warranty is automatically transferred to subsequent purchasers of the aircraft.

Seller's obligation under this Limited Warranty is limited to repairing or replacing, in Seller's sole discretion, with exchange, overhauled, or new parts, any part or parts which: (1) fail within the applicable warranty period, (2) are returned at the warranty recipient's expense to the facility where the replacement part is procured, whether through Seller Service Parts & Programs or a service facility authorized by Seller to perform service on the aircraft (collectively "Support Facility"), (3) are accompanied by a properly executed claim form, and (4) are found by Seller or its designee to be defective.

Replacement parts must be procured through a Support Facility and are only warranted for the remainder of the applicable original aircraft warranty period. A new warranty period is not established for replacement parts. The repair or replacement of defective parts under this Limited Warranty will be made by a service facility authorized by Seller to perform service on the aircraft ("Authorized Service Facility") without charge to the warranty recipient for parts and/or labor for removal, installation, and/or actual repair of such defective parts. All expedited freight, transportation expenses, import duties, customs brokerage fees, sales taxes, and use taxes, if any, on such warranty repairs or replacement parts are the warranty recipient's sole responsibility. (Location of Authorized Service Facilities will be furnished by Seller on request.)

This Limited Warranty applies to only items detailed herein which have been used, maintained, and operated in accordance with Seller and other applicable manuals, bulletins, and other written instructions. However, this Limited Warranty does not apply to items that have been subjected to misuse, abuse, negligence, accident, or neglect; to items that have been installed, repaired, or altered by repair facilities not authorized by Seller; or to items that, in the sole judgment of Seller, have been installed, repaired, or altered by other than Authorized Service Facilities contrary to applicable manuals, bulletins, and/or other written instructions provided by Seller so that the performance, stability, or reliability of such items are adversely affected. This Limited Warranty does not apply to normal maintenance services (such as engine adjustments, cleaning, control rigging, brake and other mechanical adjustments, and maintenance



## 14. LIMITED WARRANTIES (CONTINUED)

inspections); or to the replacement of service items (such as brake linings, lights, filters, hoses, belts, tires, and rubber-like items); or to normal deterioration of appurtenances (such as paint, cabinetry, and upholstery), corrosion or structural components due to wear, exposure, and neglect.

**WITH THE EXCEPTION OF THE WARRANTY OF TITLE AND TO THE EXTENT ALLOWED BY APPLICABLE LAW, THIS LIMITED WARRANTY IS EXPRESSLY IN LIEU OF ANY OTHER WARRANTIES, EXPRESSED OR IMPLIED, IN FACT OR BY LAW, APPLICABLE TO THE AIRCRAFT. SELLER SPECIFICALLY DISCLAIMS AND EXCLUDES ALL OTHER WARRANTIES, INCLUDING, BUT NOT LIMITED TO, ANY IMPLIED WARRANTY OF MERCHANTABILITY OR FITNESS FOR A PARTICULAR PURPOSE. THE AFOREMENTIONED REMEDIES OF REPAIR OR REPLACEMENT ARE THE ONLY REMEDIES UNDER THIS LIMITED WARRANTY. SELLER EXPRESSLY AND SPECIFICALLY DISCLAIMS ALL OTHER REMEDIES, OBLIGATIONS, AND LIABILITIES, INCLUDING, BUT NOT LIMITED TO, LOSS OF AIRCRAFT USE, LOSS OF TIME, INCONVENIENCE, COMMERCIAL LOSS, LOSS OF PROFITS, LOSS OF GOODWILL, AND ANY AND ALL OTHER CONSEQUENTIAL AND INCIDENTAL DAMAGES. SELLER NEITHER ASSUMES NOR AUTHORIZES ANYONE ELSE TO ASSUME ON ITS BEHALF ANY FURTHER OBLIGATIONS OR LIABILITIES PERTAINING TO THE AIRCRAFT NOT CONTAINED IN THIS LIMITED WARRANTY. THIS LIMITED WARRANTY SHALL BE CONSTRUED UNDER THE LAWS OF THE STATE OF KANSAS AND ANY DISPUTES AND/OR CLAIMS ARISING THEREFROM SHALL BE EXCLUSIVELY RESOLVED IN THE STATE AND/OR FEDERAL COURTS LOCATED IN WICHITA, KANSAS. THE PARTIES HERETO CONSENT TO PERSONAL JURISDICTION IN THE FORUM CHOSEN.**

### 14.2 PRATT & WHITNEY CANADA INC. (ABBREVIATED NEW ENGINE WARRANTY)

Pratt & Whitney Canada Inc. (P&WC) warrants that each new PT6A-140 engine complete with installed accessories at time of delivery will be free from defects in material and manufacture. P&WC's liability and purchaser's remedy under this warranty are limited to the repair or replacement at P&WC's option of goods returned to P&WC or to a location designated by P&WC which are shown to P&WC's rea-

sonable satisfaction to have been defective, provided that written notice of defect shall have been given by Purchaser to P&WC or its designee within one thousand (1,000) flying hours after delivery of the engine to the first user. The repair or replacement of defective goods under the Warranty will be made by P&WC or its designee without charge for parts or reasonable labor for removal, installation and/or actual repair of such defective goods, and reasonable transportation charges, except import duties, sales or use taxes, if any, on replacement. Transportation charges for the return of defective goods to P&WC or its designee and their re-shipment to Purchaser and the risk of loss thereof will be borne by P&WC.

**THE FOREGOING WARRANTIES ARE EXCLUSIVE AND ARE GIVEN AND ACCEPTED IN LIEU OF ANY AND ALL OTHER WARRANTIES, EXPRESSED OR IMPLIED, INCLUDING WITHOUT LIMITATION THE IMPLIED WARRANTY OF MERCHANTABILITY AND ANY OBLIGATION, LIABILITY, RIGHT, CLAIM OR REMEDY IN CONTRACT OR TORT WHETHER OR NOT ARISING FROM P&WC'S NEGLIGENCE, ACTUAL OR IMPUTED. THE REMEDIES OF THE PURCHASER FOR ANY BREACH OF WARRANTY SHALL BE LIMITED TO THOSE PROVIDED HEREIN TO THE EXCLUSION OF ANY AND ALL OTHER REMEDIES INCLUDING, WITHOUT LIMITATION, INCIDENTAL OR CONSEQUENTIAL DAMAGES. NO VARIATION OR EXTENSION OF THE FOREGOING WARRANTIES, REMEDIES OR THIS LIMITATION WILL BE BINDING UPON P&WC UNLESS APPROVED IN WRITING BY A DULY AUTHORIZED OFFICER OF P&WC.**

The above abbreviated warranty is for the purposes of the Specification and Description. For complete details of the PT6A-140 engine warranty, please refer to P&WC's full PT6A-140 warranty policy.

### 14.3 HONEYWELL/BENDIX/KING WARRANTY

A. General Aviation Avionic products manufactured by Honeywell/Bendix/King, General Aviation Division (collectively referred to herein as "Honeywell/Bendix/King") are warranted against defects in design, material or workmanship caused by Honeywell/Bendix/King or its authorized agent(s) for the Warranty Period as defined in Paragraph

## 14. LIMITED WARRANTIES (CONTINUED)

(B) of this statement which occur under normal and intended use and service, subject to all of the qualifications and conditions hereinafter stated.

1. Warranty coverage is only offered to purchasers who make warranty registrations within eighteen (18) months of the product's factory shipping date. Demonstration or stock aircraft usage is restricted to 100 hours service prior to warranty registration. Warranty coverage, therefore, may be unavailable or limited, depending upon the usage or time the product in question may have remained unsold in the custody of the O.E.M. (Original Equipment Manufacturer), his agent, or the retail dealer, a matter as to which the seller is expected to maintain accurate records and provide same, upon demand, to any purchaser or Honeywell/Bendix/King.

2. Warranty coverage for products otherwise not eligible by reason of expiration of the eighteen (18) month period specified above may again become eligible for warranty protection, provided (a) that warranty registration occurs within thirty (30) months of the product's factory shipping date and (b) that the products are submitted to Honeywell/Bendix/King for inspection and certification and then the promulgated Honeywell/Bendix/King certification fee is paid.

B. The Warranty Period for products shall begin upon the date of delivery of the product to the purchaser and shall end two years thereafter.

C. Any product Honeywell/Bendix/King finds to be in violation of the warranty as set out in Paragraph (A) hereof, at the option of Honeywell/Bendix/King, shall be repaired, replaced, or exchanged, in accordance with the following procedures:

1. Products shall be returned to an authorized Honeywell/Bendix/King Service Center or Honeywell/Bendix/King Regional Product Support Repair/Overhaul Facility, with transportation charges prepaid.

2. After correction, the products shall be returned to the purchaser with surface transportation charges prepaid, except for returns to purchasers in foreign countries.

3. The risk of loss or damage to all products in transit shall be borne by the party initiating the transportation of such products unless the purchaser makes a request for a specific mode of transportation. In such case, the risk of loss and the cost of shipment shall be borne by the purchaser.

All items repaired or replaced hereunder shall be warranted for the unexpired portion of the original Warranty Period.

D. This warranty specifically excludes defects which Honeywell/Bendix/King determines to be the result of:

1. Abuse, accident, or misuse;

2. Contamination, negligence, tampering, or improper storage or maintenance;

3. Repair or attempted repair by unauthorized persons or use of non-Honeywell/Bendix/King or unauthorized repair or replacement parts; or

4. Products not installed by an authorized Honeywell/Bendix/King Installation Facility in accordance with the appropriate installation manual.

E. The Warranty as set out in paragraph (A) is the only warranty for Honeywell/Bendix/King General Aviation Avionics Products and is in lieu of all other warranties express or implied, including the implied warranties of merchantability and fitness for a particular purpose which are herewith expressly excluded and disclaimed.

F. The remedies as set out in Paragraph (C) hereof state the entire liability of Honeywell/Bendix/King and constitute the sole and exclusive remedy of the purchaser. Honeywell/Bendix/King shall not be liable for any other claim, loss, or damage, including, but not limited to incidental, consequential, or other kinds of damages whether based on contract, tort, negligence, or other theory of product liability.

G. Honeywell/Bendix/King reserves the right to make design changes, additions to, and improvements in its products without the obligation to install same in products previously manufactured.

## 14. LIMITED WARRANTIES (CONTINUED)

### 14.4 HARTZELL PROPELLER

#### A. COVERAGE PROVIDED

##### Products Other Than De-Ice Boots

Hartzell Propeller Inc. (“Hartzell”) warrants to the original retail purchaser (the “Purchaser”) that it will repair or replace defects in material or workmanship in the components of a product manufactured by Hartzell, other than a de-ice boot, for a period of one (1) year from the date the product is first placed into service, or for the first 1000 operating hours of use of the product, whichever occurs first, subject to the other terms and conditions of this limited warranty.

##### De-Ice Boots

Hartzell warrants to the Purchaser that it will repair or replace defects in material or workmanship in the components of a de-ice boot manufactured by Hartzell, for a period of eighteen (18) months from the date the de-ice boot is first placed into service, or for the first 2000 operating hours of use of the product, whichever occurs first, subject to the other terms and conditions of this limited warranty.

All of the products identified above are hereinafter referred to as the “Products,” and their components hereinafter referred to as “Components.”

#### B. DISCLAIMER OR LIMITATION OF WARRANTIES

**Unless prohibited by applicable law, and except for the limited warranties set forth above, Hartzell hereby disclaims any and all express and implied warranties, including but not limited to implied warranties of merchantability and fitness for a particular purpose. In the event disclaimer of implied warranties is not permitted under applicable law, such implied warranties, including but not limited to implied warranties of merchantability and fitness for a particular purpose, are limited in duration and in scope of coverage to the duration and scope of coverage of the limited warranty.**

**Some states do not allow limitations on how long an implied warranty lasts, so above limitation may not apply to you.**

#### C. TERMS AND CONDITIONS OF LIMITED WARRANTY COVERAGE

In order to obtain coverage under Hartzell’s limited warranty, the Purchaser must notify Hartzell in writing of the warranty claim as soon as possible after obtaining knowledge of the potential claim, and in any event not later than ten (10) days following expiration of the limited warranty. Hartzell may withhold warranty repairs pending proof from Purchaser of the date the Product was placed into service, including a fully completed warranty registration card. Hartzell shall provide warranty repair or disposition instructions based on a written statement from the Purchaser describing the alleged defect. All initial transportation and handling charges must be prepaid by the Purchaser until warrantability is determined by Hartzell, at which time Hartzell may reimburse none, some, or all of these charges, at Hartzell’s discretion. In the event Hartzell determines, at its sole discretion, that the Product or Component thereof is covered under the limited warranty, Hartzell shall, at its election, either:

- (1) Have the Product or Component repaired and returned to Purchaser;
- (2) Deliver to Purchaser a replacement Product or Component; or
- (3) Issue a credit to the Purchaser in the amount of the actual purchase price for the Product. Hartzell reserves the right to replace Products or Components with remanufactured or re-designed Products or Components of substantially equivalent quality. All warranty repair work will be accomplished at Hartzell’s principal place of business, a Hartzell Recommended Service Facility, or a third-party location pre-approved in writing by Hartzell.

In the event Hartzell determines that the alleged defect is not covered by the limited warranty, the Product or Component will be returned to Purchaser, as is, transportation and handling charges collect. The only remedies under this limited warranty are as set forth above. Any Product repaired, or replacement Product provided, shall retain the balance of the limited warranty provided for herein. This limited warranty is not transferable to any person or entity. This limited warranty does not extend to future performance of a Product.

## 14. LIMITED WARRANTIES (CONTINUED)

### D. WHAT IS NOT COVERED BY THIS LIMITED WARRANTY

This limited warranty does not provide coverage for any of the following:

1. Normal maintenance and service.
2. Consumable Products and Components, and Products and Components that have reached the end of their normal usable life.
3. Product components not manufactured by Hartzell, which components may or may not be covered under warranties made by the manufacturers of those components.
4. Products and Components not purchased through Hartzell or one of its authorized distributors, or any Products or Components purchased by way of auction, salvage, or repossession.
5. Conditions, damage, or issues caused by, in whole or in part, or in any way related to:
  - a. Accident, misuse, theft, or negligence.
  - b. Failure to comply with any instruction provided by Hartzell or its suppliers with respect to the use, operation, maintenance, or service of the Products.
  - c. Alteration or modification of the Products or any Components.
  - d. Acts of God or other environmental conditions.
  - e. Use of the Products for purposes other than their normal use.
  - f. Failure to seek and obtain warranty coverage in a timely matter.
  - g. Deterioration or fading due to wear, exposure, or other cause, including but not limited to rust, cosmetic blemishes, and discoloration.
  - h. Acts or omissions of any person or entity other than Hartzell.

### E. DISCLAIMER OF INCIDENTAL AND CONSEQUENTIAL DAMAGES

**Hartzell hereby disclaims any and all incidental, consequential, special, direct, and indirect damages arising out of or relating to the Products, including but not limited to loss of use, inconvenience, lost profits, cover, rental replacements, costs and expenses of “troubleshooting,” and transportation and delivery expenses not pre-approved in writing by Hartzell. In no event shall Hartzell’s liability with respect to any Product, whether under this limited warranty, any implied warranty, in tort, or otherwise, exceed the price paid by Purchaser for the Product. These disclaimers are independent of any failure of the essential purpose of any warranties or remedies provided to Purchaser, and shall survive any determination that a warranty or remedy failed of its essential purpose. Some states do not allow the exclusion or limitation of incidental or consequential damages, so the above limitation or exclusion may not apply to you.**

### F. STATUTE OF LIMITATIONS

No action may be brought against Hartzell for breach of its limited warranty, any applicable implied warranty, or for any other claim relating to the Product, more than ten (10) days after expiration of the applicable limited warranty period.

### G. GOVERNING LAW

This limited warranty shall be governed by, construed, and enforced in accordance with the laws of the State of Ohio, without reference to conflict of law principles. The United Nations Convention on Contracts for the International Sale of Goods shall not apply to this limited warranty.

### H. NO AUTHORITY

No person or entity has authority to alter the terms of this limited warranty or make any warranties or representations on behalf of Hartzell. THIS WARRANTY GIVES YOU SPECIFIC LEGAL RIGHTS, AND YOU MAY ALSO HAVE OTHER RIGHTS WHICH VARY FROM STATE TO STATE.

Hartzell Propeller Inc.  
One Propeller Place Piqua, Ohio 45356  
Phone: 937-778-4320

# 15. GRAND CARAVAN EX CREW TRAINING AGREEMENT

Training for one (1) Grand Caravan EX Crew will be furnished to First Retail Purchaser (hereinafter called the "Purchaser"), subject to the following:

1. A crew shall consist of up to two (2) licensed pilots with current experience for the training sought and one (1) mechanic with A&P licenses or equivalent experience.

2. Training shall be conducted by Cessna or by its designated training organization.

a. A simulator shall be utilized which is FAA certified to provide training to proficiency in accordance with trainer's standards.

b. In lieu of a model specific simulator, training will be provided in the most appropriate type simulator available.

c. Location of training to be Wichita, Kansas, unless mutually agreed otherwise. The organization conducting the training is hereinafter called the "Trainer."

3. Training furnished shall consist of the following:

a. Flight simulation training to simulator proficiency in accordance with Trainer's standards but not to exceed seven and one half (7.5) total hours for each pilot.

b. Ground School training for each pilot and classroom instruction for each mechanic in accordance with Trainer's standards.

c. Flight training to flight proficiency in accordance with Trainer's standards not to exceed five (5) total hours per pilot, shall be conducted in the customer's aircraft.

4. Purchaser shall be responsible for:

a. Transportation of crew to and from training site and for living expenses during training.

b. Providing an interpreter during the course of training for any of Purchaser's crew not conversant with the English language.

c. Payment to Trainer for additional simulator or flight training beyond that required to attain proficiency in accordance with Trainer's standards for the course in which the pilot is enrolled.

d. All aircraft for flight training as well as all landing fees, fuel costs, aircraft maintenance and insurance and all other direct costs of operation, including applicable taxes required in connection with the operation of said aircraft during such flight training.

e. Extra charges, if any, for scheduling pilots in separate training classes.

f. Reimbursing to Cessna the retail rate for training in the event of training before actual sale/delivery, if sale/delivery is cancelled.

5. Seller or Trainer shall schedule all training, furnish Purchaser schedules of training and endeavor to schedule training at a convenient time for Purchaser. A cancellation fee of Two Hundred Dollars (\$200) will be paid by Purchaser if crew fails to appear for scheduled training, except for reasons beyond its reasonable control, unless Purchaser gives Seller written notice of cancellation received at Wichita, Kansas, at least seven (7) days prior to scheduled training. In the event of such cancellation Seller shall reschedule training for the next available class.

6. Neither Seller nor Trainer shall be responsible for the competency of Purchaser's crew during and after training. Trainer will make the same efforts to qualify Purchaser's crew as it makes in training of other Caravan crews; however, Seller and Trainer cannot guarantee Purchaser's crew shall qualify for any license, certificate or rating.

7. Neither Seller nor Trainer shall be responsible for any delay in providing training due to causes beyond its or their reasonable control.

8. All Training furnished to Purchaser under the Agreement will be scheduled to commence no earlier than three (3) months prior to delivery and will be completed within twelve (12) months after delivery of the aircraft unless mutually agreed otherwise.

Signature of the Purchaser to the Purchase Agreement to which this Training Agreement is attached as a part of the Specification and Description shall constitute acceptance by Purchaser of the foregoing terms and conditions relative to training to be furnished by Seller.



**U.S. + 1.844.44.TXTAV | INTERNATIONAL +1.316.517.8270 | TXTAV.COM**

© 2016 Textron Aviation Inc. The names of aircraft manufactured by Textron Aviation Inc. ("TAI") (or formerly by its subsidiaries Cessna Aircraft Company ("Cessna") and Beechcraft Corporation ("Beechcraft") including Hawker aircraft); some names for products or services of TAI, Cessna, Beechcraft or their subsidiaries, and logos are registered trademarks or registered service marks or trademarks or service marks of Textron Innovation Inc., used by permission, or Beechcraft whether or not appearing in large print, with trade marking symbols or otherwise denoting rights to or ownership of the same. Third party products names, marks, etc., whether or not appearing in large print or with trade marking symbols or otherwise denoting right or ownership of the same, belong to their respective owners.

February 2016  
S&D-208B-0216